

# Service Schematics

## NOKIA 5630 XPRESSMUSIC RM-431

### Introduction

#### Important:

This document is intended for use by authorized service centers only.

“Service Schematics” was created with focus on customer care.  
The purpose of this document is to provide further technical repair information for NOKIA mobile phones on Level 3/4 service activities.  
It contains additional information such as e.g. “Component finder”.

Saving process time and improving the repair quality is the aim of this document.  
It is to be used additionally to the service manual and other training or service information such as Service Bulletins.

While every endeavour has been made to ensure the accuracy of this document, some errors may exist. If the reader finds any errors, NOKIA should be notified in writing.

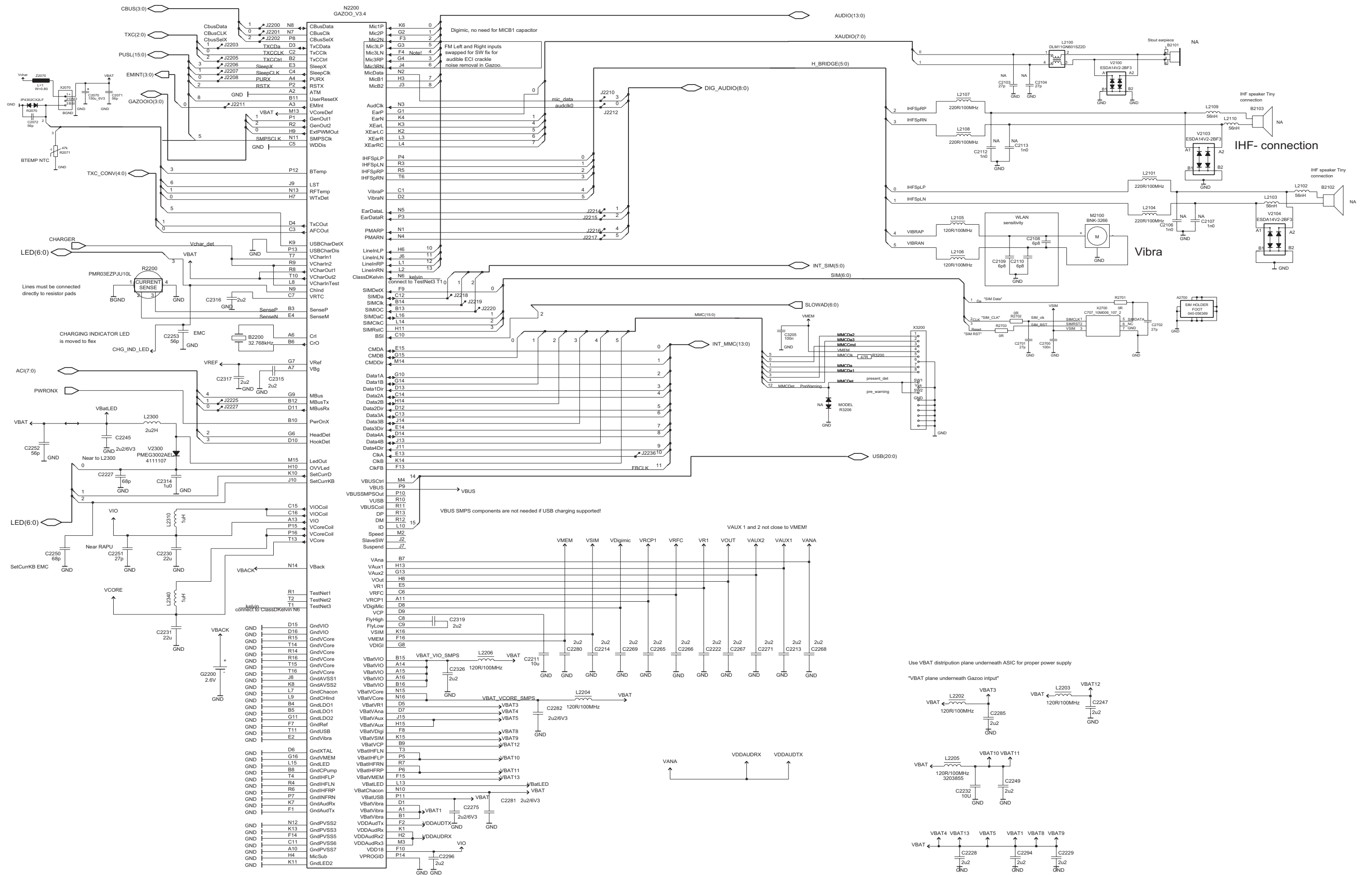
Please send E-Mail to: [TrainingAndVendor.Development@nokia.com](mailto:TrainingAndVendor.Development@nokia.com)

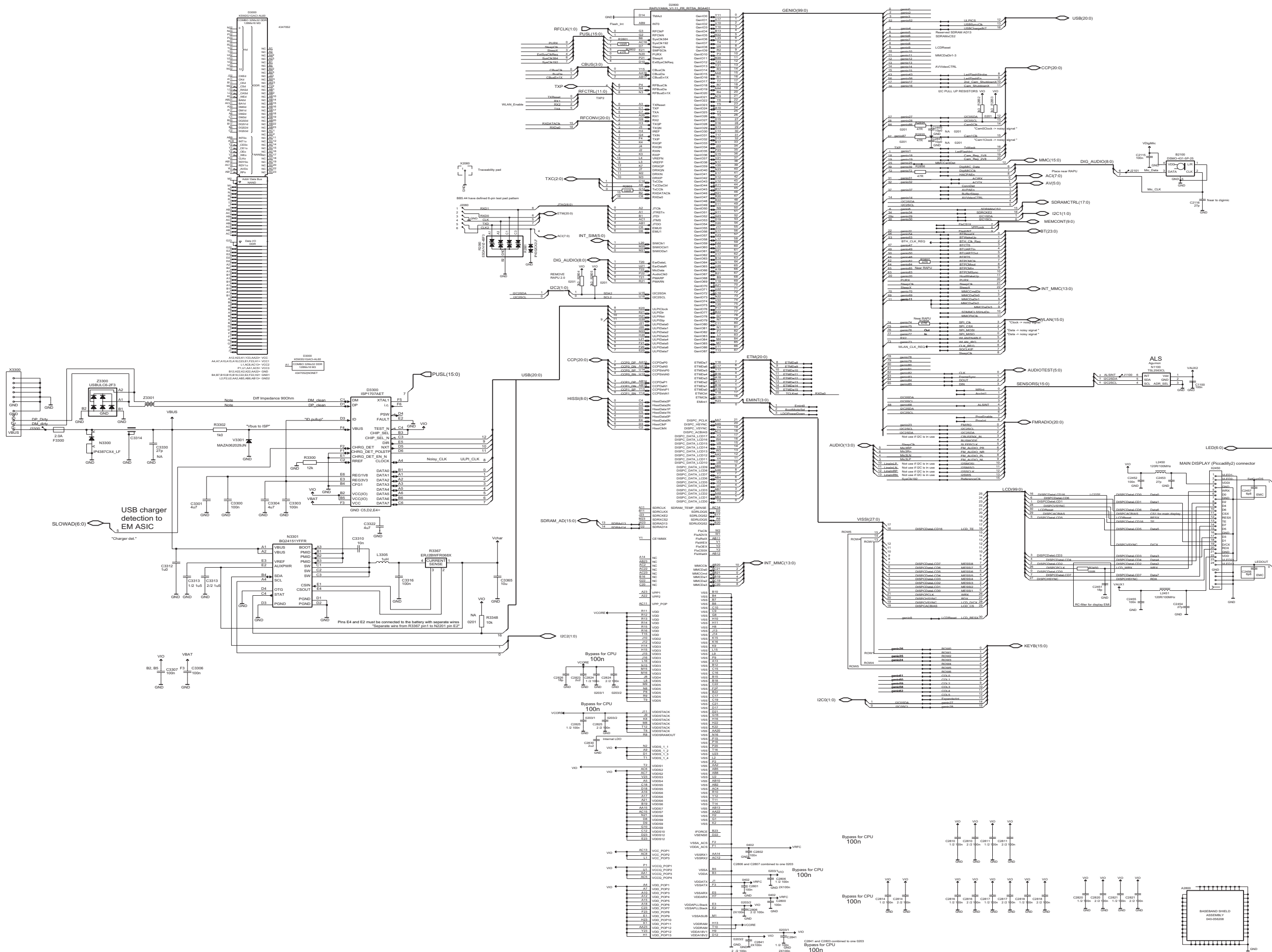


Table of contents	
Frontpage	1
GAZOO, HS USB charging, SIM, MMC, Audio	2
MUX, RAPU-YAMA, Memory, UI	3
AV Connector	4
Bluetooth, WLAN	5
Keyboard	6
RF	7
Cameras	8
Component Finder	9

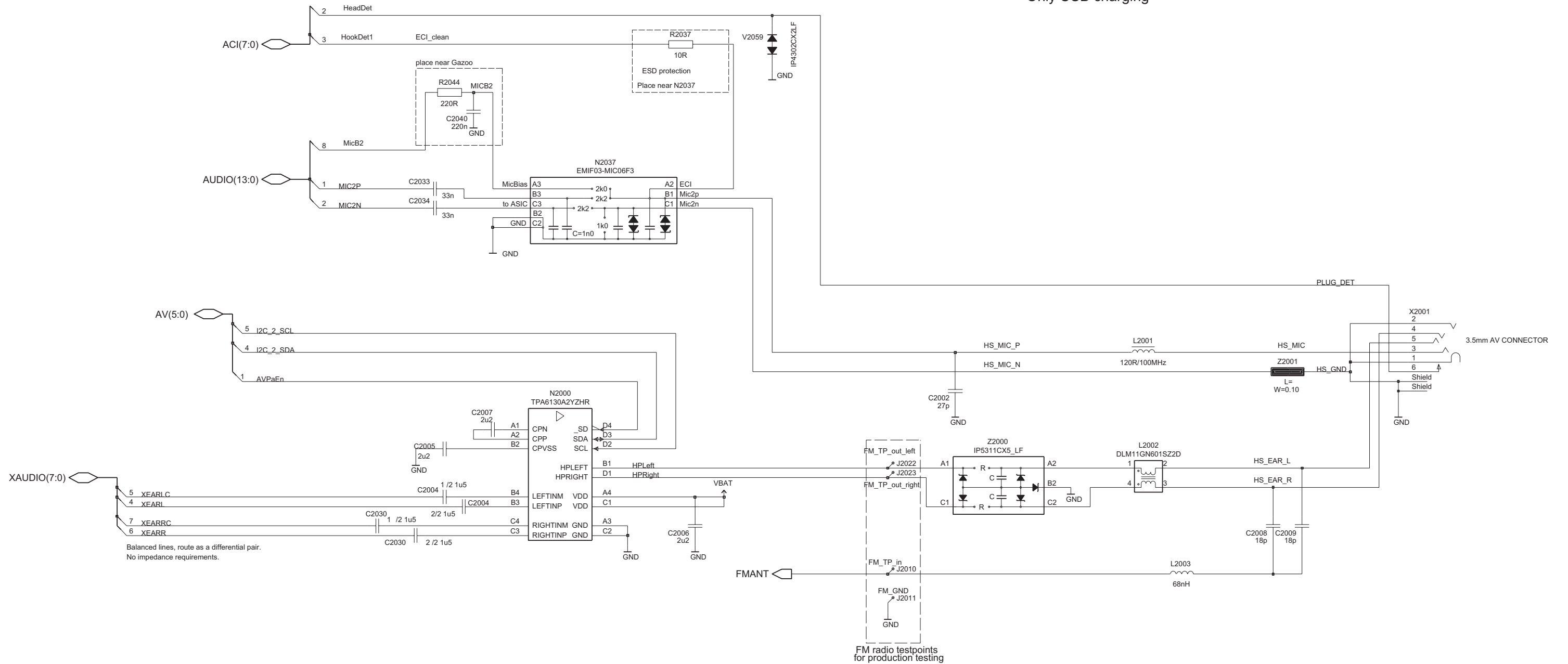
Copyright © NOKIA

This material, including documentation and any related computer programs is protected by copyright, controlled by NOKIA. All rights are reserved. Copying, including reproducing, modifying, storing, adapting or translating any or all of this material requires the prior written consent of NOKIA. This material also contains confidential information, which may not be disclosed to others without the prior written consent of NOKIA.



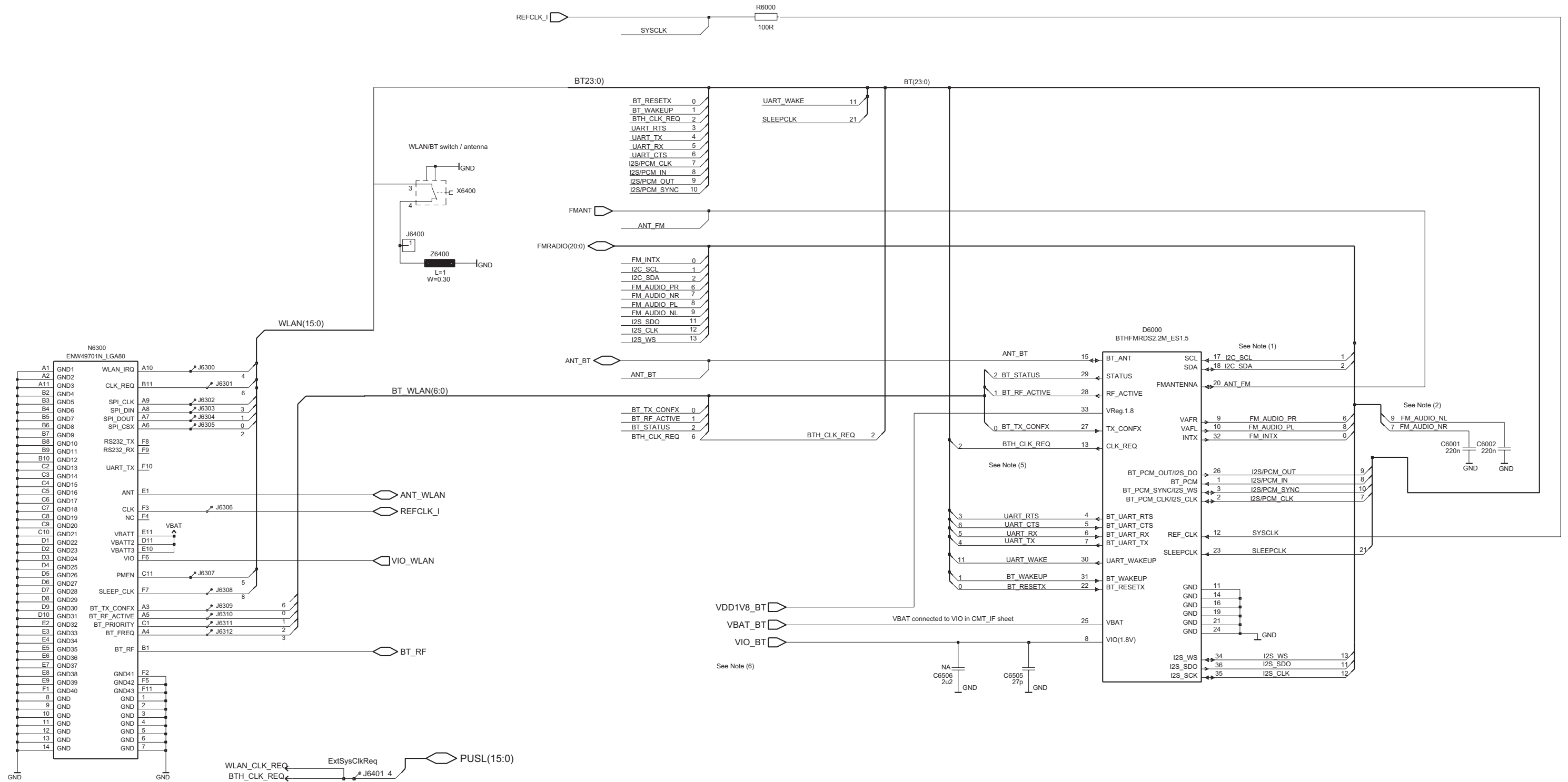


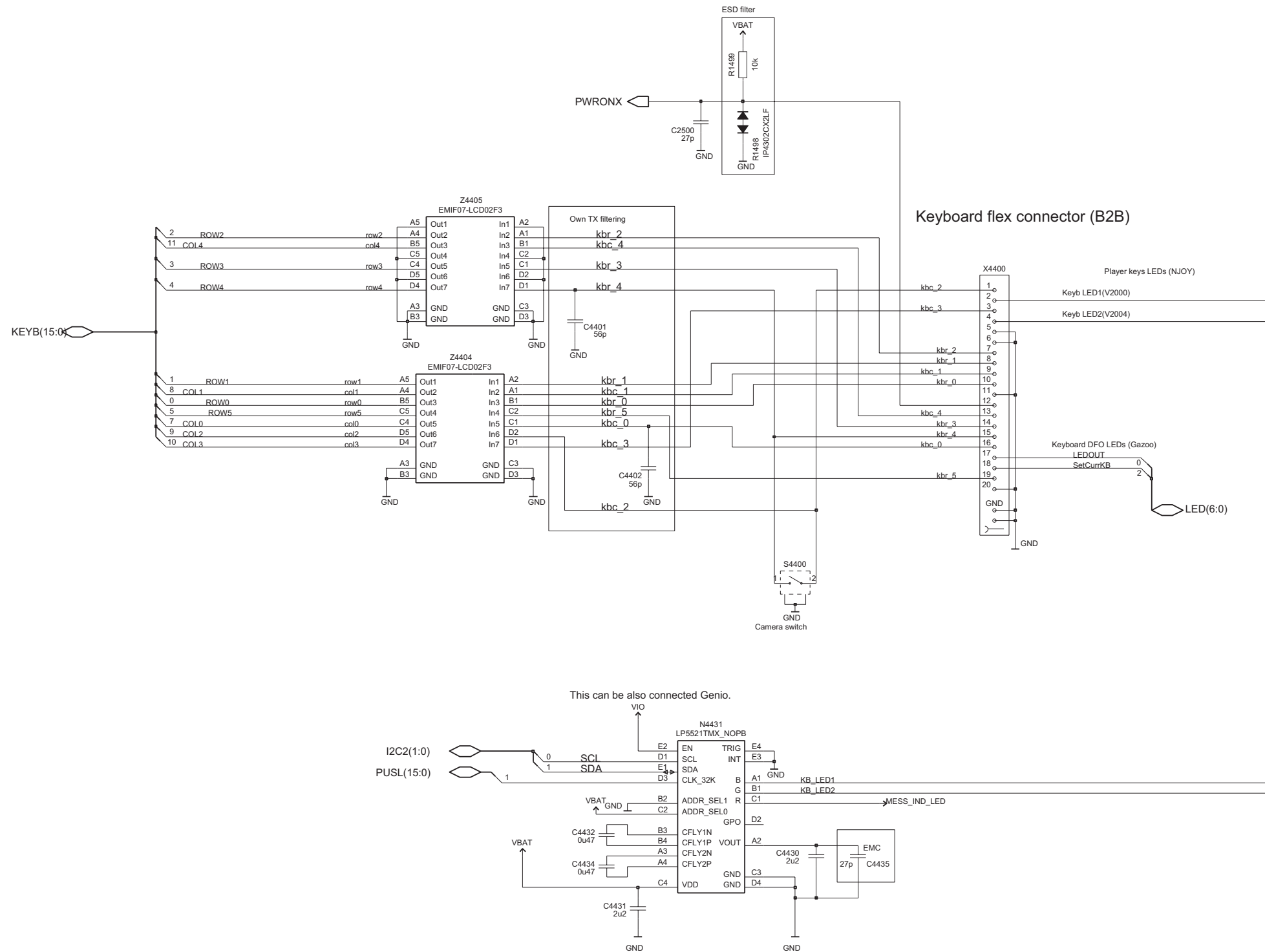
Only USB charging





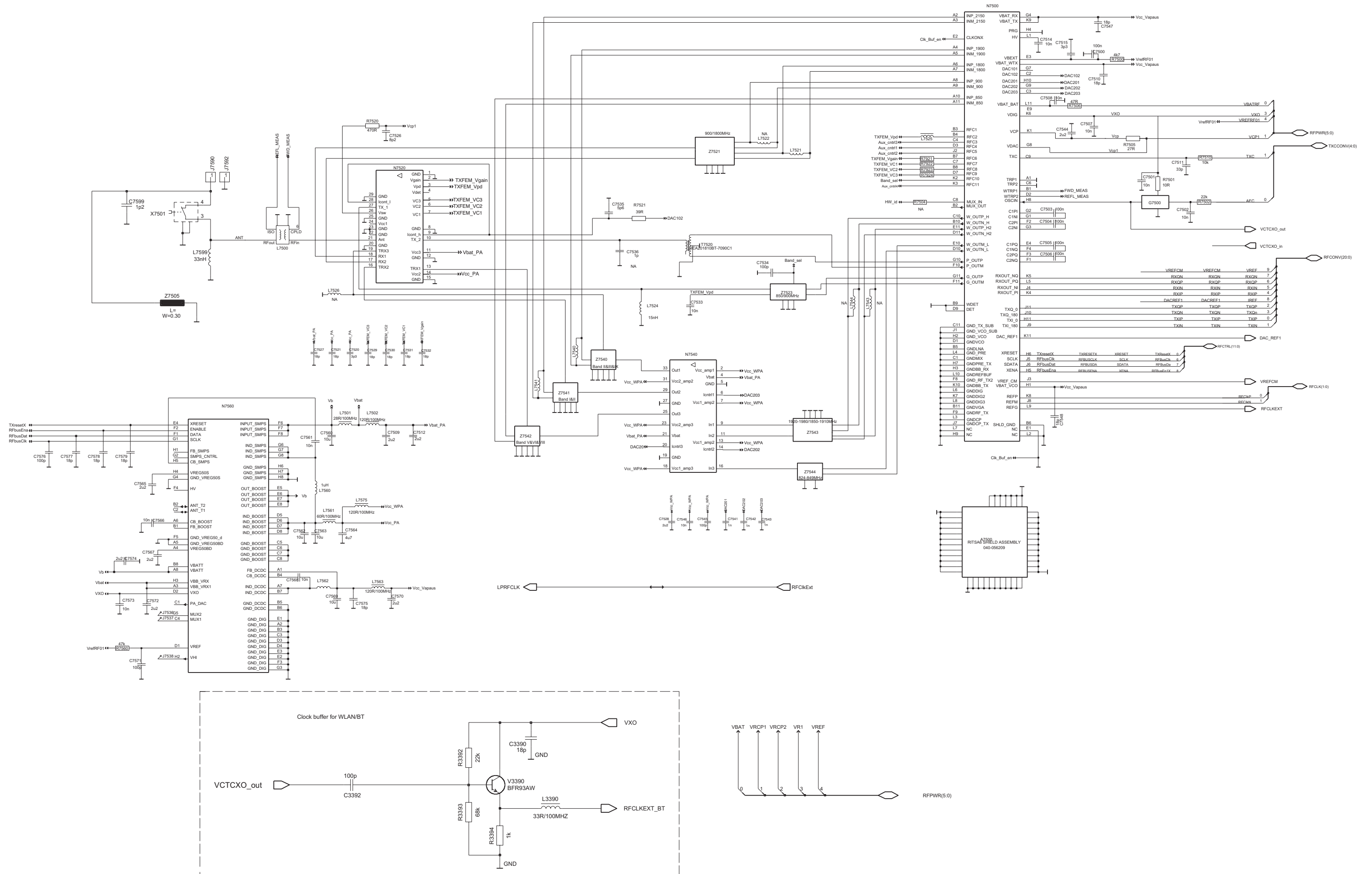
BLUETOOTH & FM RADIO MODULE WITHOUT RF FILTER

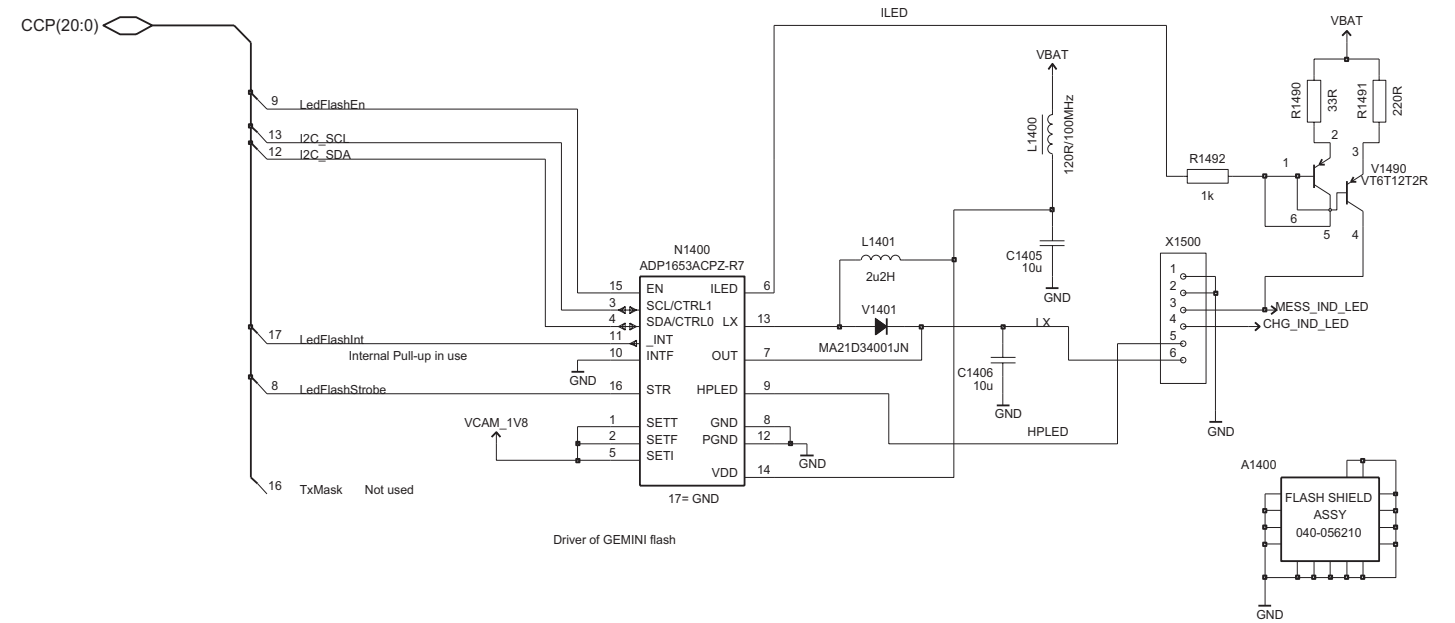
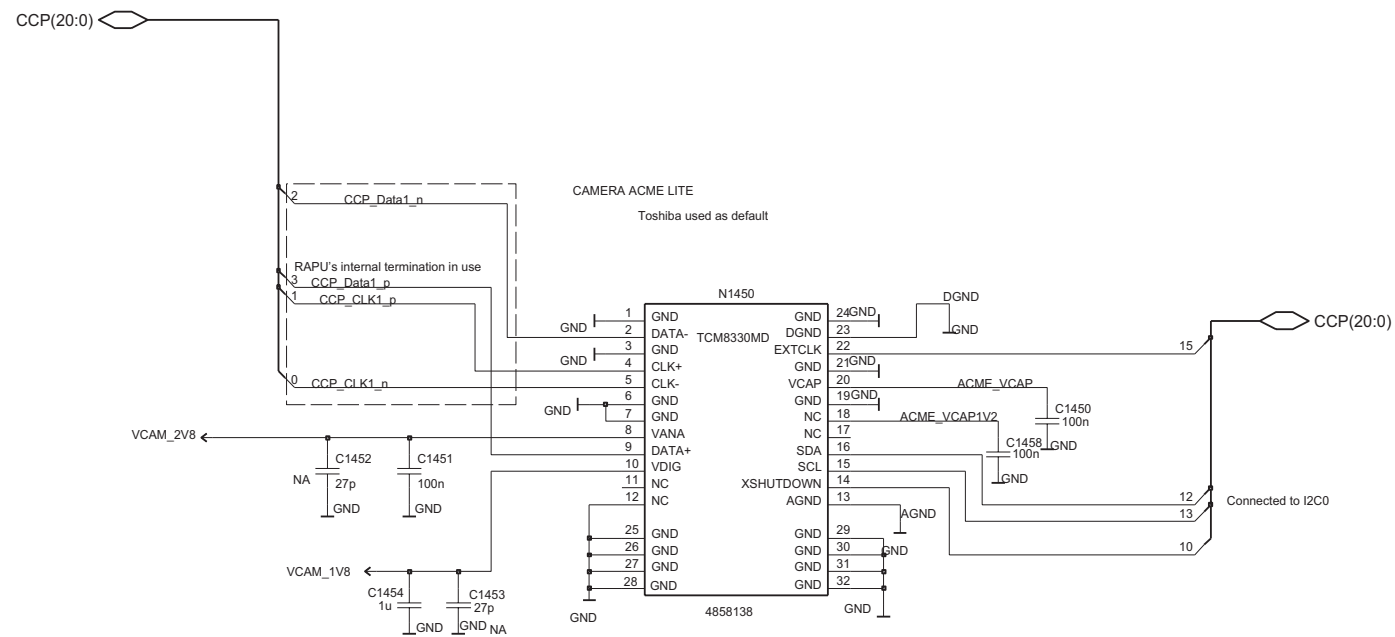
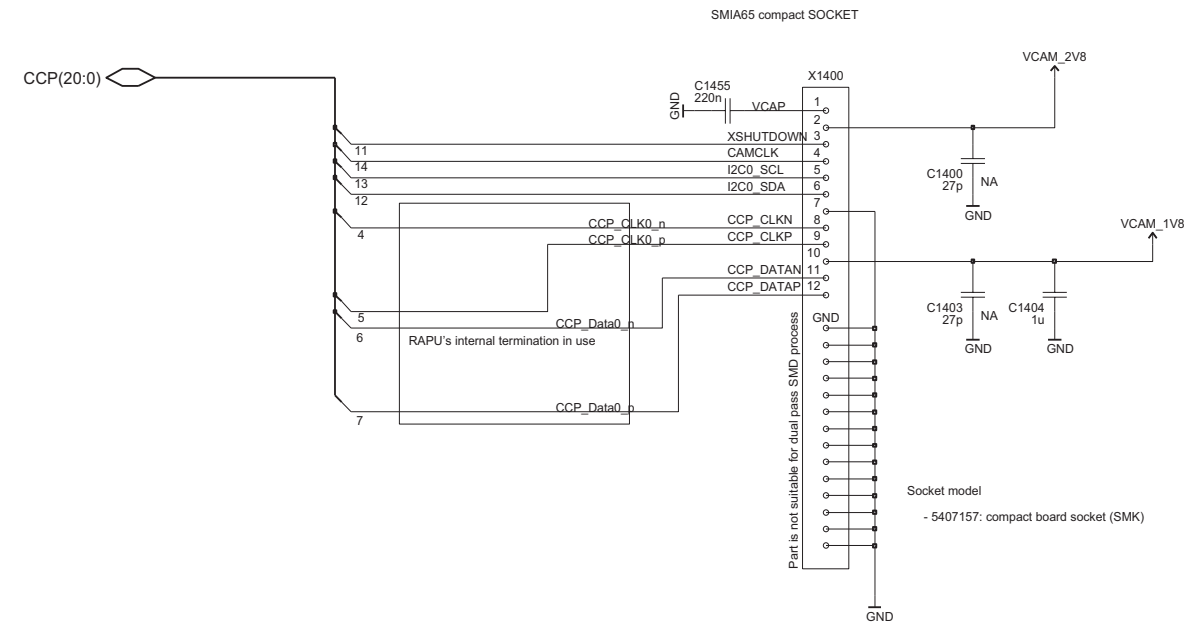
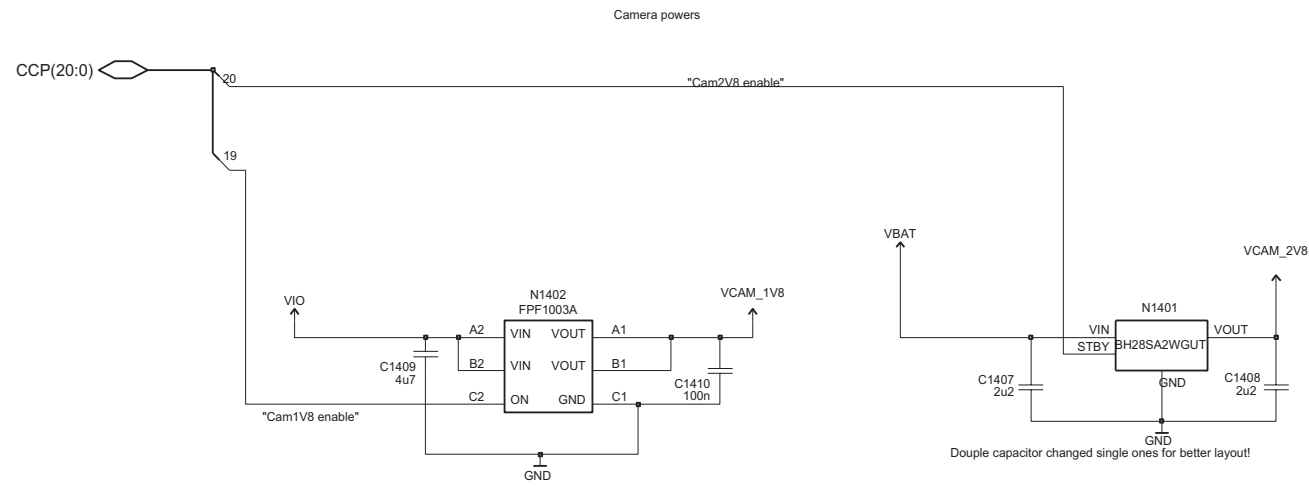




Key matrix

	COL0	COL1	COL2	COL3	COL4
ROW0	Vol Up SK	1	2	3	RightSK UI
ROW1	Vol Down SK	4	5	6	LeftSK UI
ROW2	NOT USED	7	8	9	CLEAR UI
ROW3	NaviSELECT UI	*	0	#	APPS UI
ROW4	NaviUP UI	SEND UI	Camera SK	NOT USED	NaviDOWN UI
ROW5	NaviRIGHT UI	MK1 MK	MK2 MK	MK3 MK	NaviLEFT UI







<b>A</b>	C2281	G 8	C6505	T 4	G7500	D2	N7560	C 8	<b>X</b>	
A1400	R 7	C2282	F 8	C7500	B 3	<b>J</b>	<b>R</b>	X1400	R 5	
A2700	E 5	C2285	H 7	C7501	D 2	J6400	T 2	R1490	T 5	
A2800	G 5	C2294	H 7	C7502	D 2	J7590	A 7	R1491	T 6	
A7500	C 5	C2296	F 7	C7503	B 2	J7592	A 7	R1492	Q 7	
<b>B</b>	C2314	E 8	C7504	B 2	<b>L</b>	R1498	F 9	X2070	ZF 7	
B2100	A 4	C2315	G 6	C7505	B 3	L1400	Q 6	R1499	G 9	
B2200	G 7	C2316	H 7	C7506	B 2	L1401	R 6	R2037	T 7	
<b>C</b>	C2317	H 8	C7507	C 2	L2001	U 8	R2044	H 8	X3200	E 3
C1100	U 2	C2319	G 7	C7508	D 2	L2002	T 7	R2060	H 5	
C1404	R 4	C2326	F 7	C7509	B 7	L2003	U 7	R2061	H 6	
C1405	R 6	C2451	I 4	C7510	D 2	L2100	U 7	R2070	F 5	
C1406	R 7	C2452	H 1	C7511	E 3	L2101	H 7	R2071	U 6	
C1407	T 3	C2453	G 1	C7512	B 4	L2102	C 5	R2200	F 7	
C1408	T 3	C2454	H 3	C7514	C 2	L2103	C 5	R2450	H 4	
C1409	T 3	C2455	I 3	C7515	C 3	L2104	H 8	R2701	D 7	
C1410	T 3	C2456	H 1	C7520	C 7	L2105	H 7	R2702	D 7	
C1450	U 3	C2457	G 2	C7521	C 6	L2106	H 7	R2703	D 7	
C1451	U 2	C2500	G 9	C7526	E 5	L2107	H 8	R2801	H 5	
C1454	U 3	C2700	E 7	C7527	C 7	L2108	H 8	R2802	F 6	
C1455	S 6	C2701	D 7	C7528	B 5	L2109	B 5	R2803	I 6	
C1458	T 3	C2702	D 7	C7529	E 6	L2110	B 5	R2804	H 5	
C2002	U 7	C2800	F 3	C7530	E 6	L2202	H 7	R2805	H 5	
C2004	T 9	C2801	E 5	C7531	E 6	L2203	E 7	R2852	E 5	
C2005	T 8	C2802	F 3	C7532	E 6	L2204	F 8	R2853	E 5	
C2006	T 8	C2806	F 3	C7533	E 6	L2205	G 8	R2854	H 4	
C2007	T 8	C2810	H 6	C7534	D 3	L2206	F 7	R2855	H 4	
C2008	U 7	C2811	H 5	C7535	C 3	L2300	E 7	R2856	I 4	
C2009	U 7	C2814	H 4	C7541	E 4	L2310	F 6	R2857	H 4	
C2030	T 9	C2816	G 3	C7542	D 3	L2340	E 8	R2858	G 6	
C2033	T 7	C2817	G 3	C7543	B 4	L2450	H 1	R3200	F 5	
C2034	T 8	C2818	F 3	C7544	B 2	L2451	H 3	R3300	F 2	
C2040	H 8	C2820	E 4	C7545	E 5	L3305	Q 8	R3302	G 2	
C2070	E 7	C2821	E 5	C7546	B 4	L3390	F 1	R3367	R 8	
C2071	F 7	C2823	F 6	C7547	C 2	L7500	C 6	R3392	E 2	
C2072	F 5	C2824	E 6	C7548	C 2	L7501	E 8	R3393	E 1	
C2108	I 7	C2825	E 6	C7560	E 8	L7502	C 7	R3394	F 1	
C2109	I 7	C2826	E 5	C7561	D 8	L7521	C 3	R6000	T 4	
C2110	I 7	C2830	H 4	C7562	D 8	L7524	E 3	R7500	B 3	
C2115	A 3	C2841	E 4	C7563	D 8	L7525	C 3	R7501	E 2	
C2116	A 4	C3100	F 4	C7564	E 7	L7540	D 5	R7502	E 2	
C2211	H 7	C3205	F 4	C7565	D 8	L7541	B 5	R7505	C 2	
C2213	F 8	C3300	G 3	C7566	C 8	L7560	D 8	R7506	E 4	
C2214	F 8	C3301	F 3	C7567	C 8	L7561	E 7	R7510	E 3	
C2222	H 7	C3303	G 2	C7568	C 8	L7562	B 8	R7520	E 6	
C2227	F 8	C3304	G 3	C7569	B 8	L7563	B 3	R7521	C 3	
C2228	F 8	C3306	G 2	C7570	B 2	L7575	E 5	R7560	D 8	
C2229	H 7	C3307	F 3	C7571	C 8	L7599	A 7	R7921	D 3	
C2230	E 6	C3310	Q 8	C7572	D 8	<b>M</b>	R7922	D 3		
C2231	F 8	C3312	R 8	C7573	C 8	M2100	R 3	R7923	D 3	
C2232	G 8	C3313	S 8	C7574	C 8	<b>N</b>	R7924	D 3		
C2245	E 7	C3314	U 4	C7575	B 3	N1100	U 2	<b>S</b>		
C2247	F 7	C3316	R 8	C7576	B 3	N1400	R 7	S4400	C 1	
C2249	H 8	C3322	R 8	C7577	B 3	N1401	T 3	<b>T</b>		
C2250	E 8	C3365	S 8	C7578	B 3	N1402	T 3	T7520	D 3	
C2251	F 6	C3390	E 1	C7579	B 4	N1450	U 3	<b>V</b>		
C2252	E 7	C3392	E 2	C7599	A 7	N2000	T 8	V1401	R 7	
C2253	H 8	C4401	D 7	<b>D</b>	N2037	U 8	V1490	T 6		
C2265	F 7	C4402	D 7	D2800	G 5	N2200	G 8	V2059	S 8	
C2266	F 6	C4430	H 5	D3000	G 5	N3300	U 4	V2100	U 7	
C2267	H 7	C4431	I 5	D3300	F 2	N3301	R 8	V2103	H 9	
C2268	G 6	C4432	I 5	D6000	T 5	N4431	I 5	V2104	H 9	
C2269	H 8	C4434	I 5	<b>F</b>	N6300	S 2	V2300	F 8		
C2271	F 7	C4435	H 6	F3300	U 4	N7500	C 2	V3301	G 3	
C2275	F 8	C6001	S 6	<b>G</b>	N7520	D 6	V3390	F 2		
C2280	F 7	C6002	S 6	G2200	C 9	N7540	D 4			

